

---

# BATTISTI CUSTOMS

# SPRINTER BUS

---



[WWW.BCSPRINTER.COM](http://WWW.BCSPRINTER.COM)

---

# THE SPRINTER BUS SERIES



**REDEFINING  
LUXURY  
TRANSPORTATION**



## BATTISTI CUSTOMS SPRINTER BUS EXECUTIVE SHUTTLES & LIMOUSINES

FROM CONCEPTION TO REALIZATION, BATTISTI CUSTOMS  
SPRINTER BUSES ARE DESIGNED WITH YOU IN MIND.



# INTRODUCING THE INNOVATIVE BATTISTI SPRINTER BUS

## CONCEPTION

BUILT ON A MERCEDES SPRINTER CAB CHASSIS, THE BATTISTI CUSTOMS SPRINTER BUS ALLOWS YOU TO MAINTAIN THE SLEEK ELEGANT STYLE OF A MERCEDES SPRINTER VAN BUT WITH DIMENSIONS AND COMPONENTS THAT ARE *DESIGNED WITH YOU IN MIND*



## INNOVATION

THE SPRINTER BUS FEATURES A GALVANEEL STEEL FRAME BODY FOR MAXIMUM BODY STRUCTURAL DURABILITY AND PRODUCT LONGEVITY. THE REAR LUGGAGE AREA'S FLOOR DROPS BELOW THE BUS FLOOR TO ALLOW FOR MAXIMUM LUGGAGE CAPACITY WHILE PROVIDING LARGER AISLE SPACES AND A ROOMY ATMOSPHERE FOR PASSENGERS.

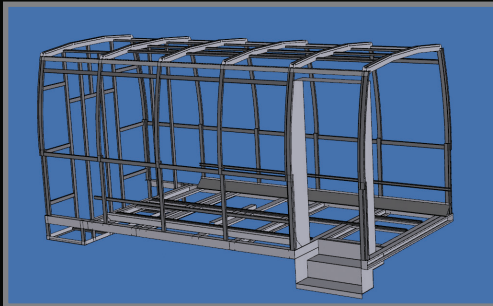

Full perimeter galvaneel steel frame is engineered to guarantee structural integrity and durability

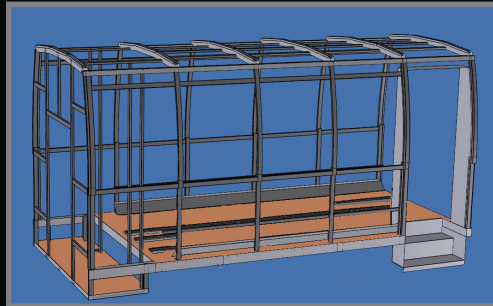

Corrosion free composite flooring ensures product longevity

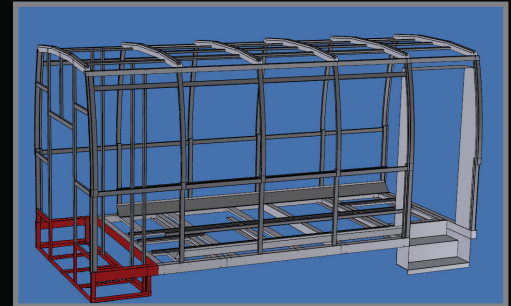

Rear Luggage compartment floor goes beneath Sprinter Bus floor to maximize passenger space without taking away luggage space.

A LIGHTWEIGHT FIBERGLASS BODY ENSURES THAT MAX CAPACITY CAN BE REACH WHILE STILL STAYING WITHIN DOT WEIGHT RESTRICTIONS. ADD THE ALCOA WHEEL SIMULATORS, AND YOU CAN INCREASE FUEL ECONOMY, DECREASE THE NORMAL WEAR AND TEAR ON YOUR AXLE AND SUSPENSION PARTS, AND SAVE AT LEAST AN ADDITIONAL 60LBS. IN WEIGHT.

THE SPRINT BUS BODY IS STILL INCLUSIVE OF ALL MERCEDES FACTORY BADGING AND TAILLIGHTS WHILE OFFERING LARGER DIMENSIONS THAT GIVE IT AN EXTRA 9" IN HEIGHT, 10" IN WIDTH AND AN EXTRA 18" IN LENGTH.



## REALIZATION

WITH ITS UNIQUE DESIGN CONCEIVED THROUGH YEARS OF CUSTOMER FEEDBACK AND INNOVATIVE ENGINEERING, WE HAVE BEEN ABLE TO FINALLY DELIVER A SPRINTER BUS BODY THAT IS SPECIFICALLY *DESIGNED WITH YOU IN MIND!*





# SPRINTER BUS EXECUTIVE SHUTTLE

## SPRINTER BUS SHELL FEATURES

- FIBERGLASS COMPOSITE BODY WITH REPLACEABLE IMPACT ZONE PANELS
- FULL MERCEDES GREY/WHITE BODY PAINT
- GALVANNEAL ANTI-CORROSION CAGE CONSTRUCTION
- LIGHT WEIGHT CORROSION FREE COMPOSITE FLOORING
- EGRESS BONDED FRAMELESS WINDOWS WITH RED LED ESCAPE MARKER LIGHTS
- 29" X 88" BIFOLD BUS DOOR TINTED BLACK WINDOWS WITH BLACK ANODIZED FRAMES WITH EMERGENCY ESCAPE LATCH
- ROOF ESCAPE HATCH
- BODY UNDERCOATING PACKAGE
- FRONT, REAR, AND SIDE CLEAR LENS LED MARKER LIGHTS
- SPRINTER FACTORY REAR TAIL LIGHTS
- LICENSE PLATE HOLDER WITH LED ILLUMINATION LIGHT AND REAR MERCEDES BADGE PACKAGE
- DUAL REAR WHEELS WITH CHROME WHEEL SIMULATOR PACKAGE
- INSULATION PACKAGE SIDEWALLS AND CEILING

## 14 PASSENGER + DRIVER/COPILOT SPRINTER BUS G2 LIMOUSINE

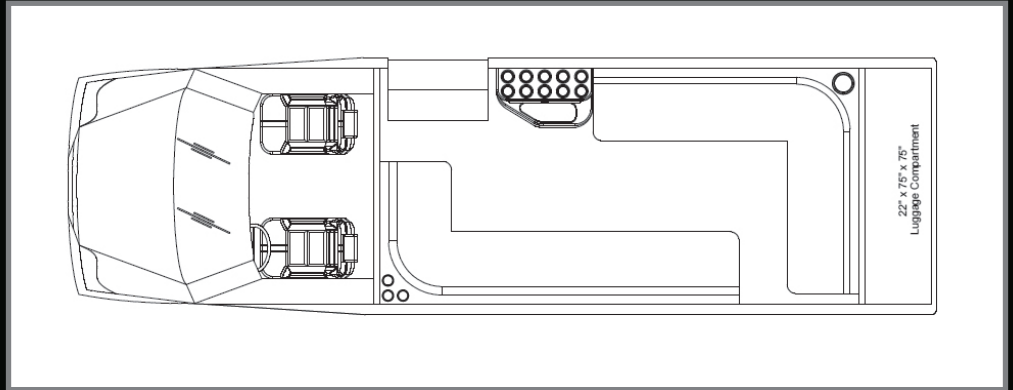

## SPRINTER BUS CHASSIS FEATURES

- BLUE TEC 3.0LTR V6 TURBO DIESEL ENGINE WITH 20MPG
- POWER MIRRORS/CRUISE/PW/PL
- MERCEDES BADGING PACKAGE WITH CHROME TRIM GRILL
- 2ND FACTORY BATTERY
- AUX BRACKET FOR 2ND COMPRESSOR
- X18 SUSPENSION PACKAGE II
- SPARE TIRE AND UNDER BODY CARRIER
- FACTORY HIGH IDLE
- 36" X 68" REAR LUGGAGE DOOR WITH ALARM
- BACK-UP ALARM
- BUS ELECTRICAL SYSTEM
- TOUCH SCREEN STEREO WITH DVD/ CD/ IPOD / AMFM / MP3 / USB / BLUE TOOTH
- (4) REAR 6.5" SPEAKERS
- REAR 3RD BREAK LIGHT BACK-UP CAMERA
- 66,000 BTU AIR/HEAT SYSTEM WITH 2ND COMPRESSOR/3 FAN CONDENSER/FREE BLOW EVAPORATOR/DIGITAL DRIVER THERMOSTAT CONTROL
- BLACK GERFLOOR NON-SKID SOUND DAMPENING COACH FLOORING

## 13 PASSENGER + DRIVER/COPILOT SPRINTER BUS EXECUTIVE SHUTTLE

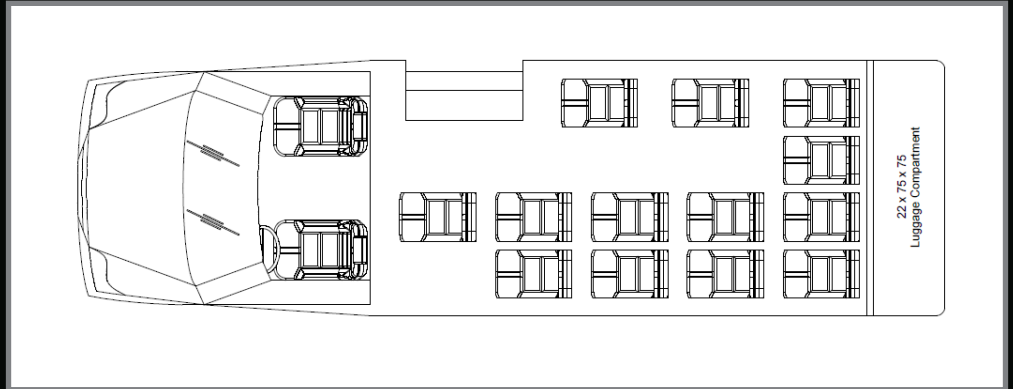

BATTISTI CUSTOMS, INC  
2994 PAUL DRIVE  
ELKHART, IN 46514  
INFO@BCSPRINTER.COM  
OFFICE: 574.262.5466  
FAX: 574.206.0024

[WWW.BCSPRINTER.COM](http://WWW.BCSPRINTER.COM)